

## Model: X2E-E170

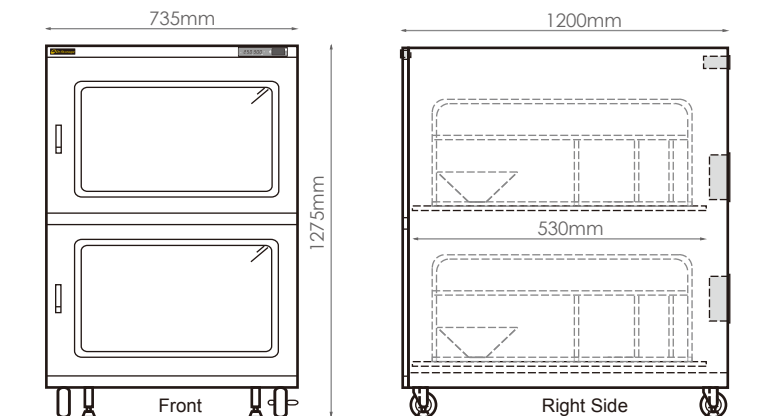

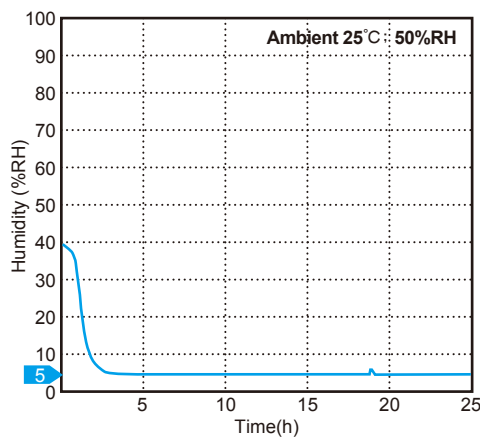

Performance chart



## Specifications:

- Humidity range :  $\leq 5\%RH$
- External size : W735\*D1200\*H1275mm
- Internal size : W618\*D1156\*H1100mm
- Capacity : 748L
- Slide shelves : 2 pcs(each shelf can hold 100kgs)
- Display precision :  $\pm 3\%RH; \pm 1^{\circ}C$
- Resolution : 0.1%RH; 0.1°C
- Humidity management software : Humidity Manager for drawing the curve of RH and Temp.
- RS-232 port : Yes
- Buzzer & Flash alarm : Yes
- Cabinet color : Black
- Cabinet structure : 1mm carbon steel with antistatic paint.
- Doors : 2 pcs, antistatic glass windows, gray window frames, compressing handles and airtight magnetic sealers.
- Wheels : 4 antistatic 3" wheels, two of them with brakes.
- Grounding wire : 1.0M $\Omega$ .(Length 2.0M)
- Static dissipative range :  $10^3 \sim 10^9 \Omega$  (surface resistance)
- Power consumption : Ave. 105W/h; Max. 305W
- Voltage : 110V/230V(select in advance)
- The best performance is achieved under the ambient condition below 25°C and 50%RH.

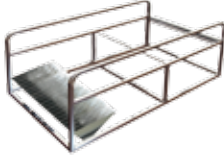
## Accessories (option):

Item	①	②	③
Item No.	0-51-0800-06	0-51-0800-07	0-60-0022-01
Item Name	Feeder rack	Feeder rack	GT02 Data logger
Description	Panasonic feeder model: KXFWLKS5A00	Yamaha feeder model: KHJ-MC100-006	Memory capacity 40,000 records.
Picture			

Item	④	⑤
Item No.	0-60-0016-01(110V) 0-60-0016-03(230V)	0-60-0010-01
Item Name	QDN	Flow meter
Description	The nitrogen will stop as soon as the relative humidity reaches preset value. Inlet dia. : $\varnothing$ 8mm	Spec:1-25L/min Inlet dia. : $\varnothing$ 8mm
Picture	